



We lead the way by a new business model

ISO 9001 ISO 14001



TOYODA qualified class,
precise manufacturing

WELE



WELE MECHATRONIC CO., LTD
(<http://www.welegroup.com>)

HEADQUARTERS:
458, Shinsing Rd., Hukou Town, Hsin-Chu County, Taiwan 303
TEL : +886-3-696-0360 (rep.) FAX : +886-3-696-0370

TAICHUNG FACTORY:
No.558-1, Shenjhou Rd., Shengang Town, Taichung County,
Taiwan 429
TEL : +886-4-2520-1173 FAX : +886-4-2520-5908

WELE MECHATRONIC (SU-ZHOU) CO., LTD.

No. 8, Ma-Qiao Industrial Block, Chang-Shu Economic
Development Zone, Chang-Shu City, Jiang-Su Province,
215513, China
TEL : +86-512-5229-7868 FAX : +86-512-5229-7866
SALES: 150-5141-3969,150-5141-3981

AAA80SERIES

Vertical Machining Center



WELE MECHATRONIC CO., LTD
A TOYODA Strategic Alliance Company

AA1480	AA1680	AA1880	AA 65 Series	AA 80 Series	AA 90 Series	AQ 50 Series	AQ 60 Series	UG Series	
			RB Series	SB Series	LB Series	MB Series	HB Series	UB Series	MG Series

Contents

The precision vertical machining center	2
Equipment	3-4
Sturdy machine base	
The full equipment	
Guides, drives, spindles	5-6
Guides and drives	
Spindles	
User-friendly down to the last detail	7
Ergonomic design	
Easy-clean	
High efficiency cutting performance	8
Strictly quality assurance	9-10
Technical specifications	11-12
Specifications	
Standard and optional accessories	
Dimensions	13-14

AA 80 series

The machine series developed for the demanding, high performance medium heavy cutting tools. Fitted with generously sized sliding guides and equipped with a mechanical, two speeds geared head as standard which is directly coupled to the precision spindle.

AA1480

AA1680

AA1880

The precision vertical machining center



Vertical cutting to WELE standard

Powerful digital servo feed drives - coupled with pre-tension ball screws - provide superior dynamic response and precision. Active and effective protection for the guides from chip and dirt comes from the slide-along telescopic guard rails.

The two speeds mechanical geared head, combined with high performance AC main drive motor, provides high speeds as well as powerful torque. Additional to this, an oil cooler ensure the machining center also keep its thermal stability when spindle running constantly.

Two Y direction screw type conveyors and a X direction caterpillar type conveyor have been incorporated into the working envelope to ensure that the chip is efficiently discharged from the machine. A central lubrication system which does the lubricant on all guideways and ball screws according to the timing and stroke, which reduces the requiring maintain work to a minimum.

The positions of the three sliding axis X, Y and Z are aligned at the factory using scraping skill and laser interferometer measurement. This guarantee the ultraprecision even with interpolated axes.

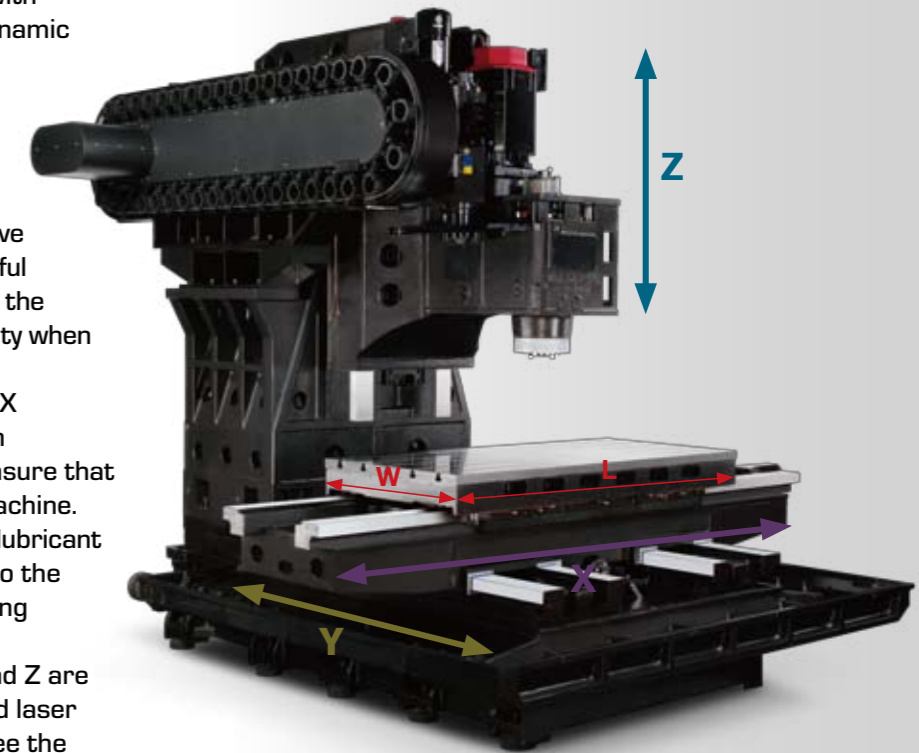

		AA1480	AA1680	AA1880
Strokes				
X travel (left & right)	mm(in)	1400(55.1)	1600(63)	1800(70.9)
Y travel (in & out)	mm(in)	800(31.5)	800(31.5)	800(31.5)
Z travel (up & down)	mm(in)	700(27.6)	800(31.5)	800(31.5)
Table dimensions				
L	mm(in)	1550(61)	1750(68.9)	1950(76.8)
W	mm(in)	800(31.5)	800(31.5)	800(31.5)
Table load capacity	kg(lb)	1800(3960)	2000(4400)	2200(4840)

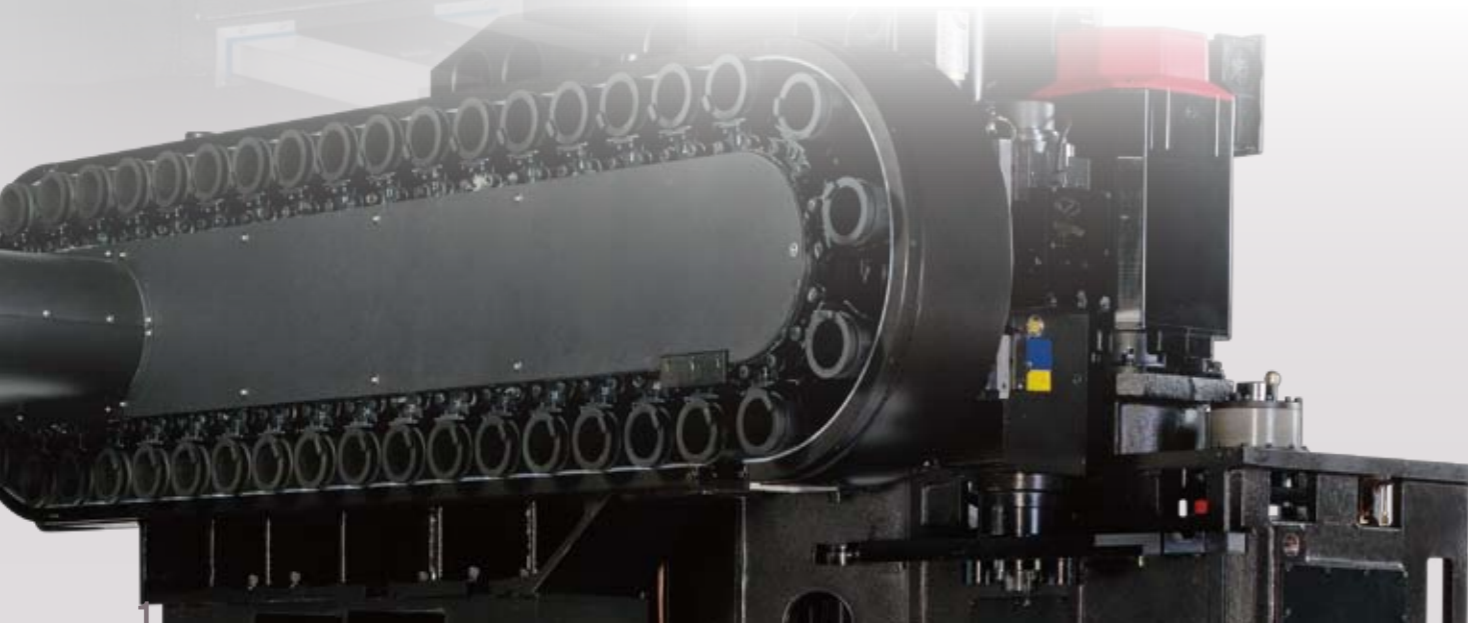

AA1480	AA1680	AA1880	AA 65 Series	AA 80 Series	AA 90 Series	AQ 50 Series	AQ 60 Series	UG Series	
			RB Series	SB Series	LB Series	MB Series	HB Series	UB Series	MG Series

Equipment

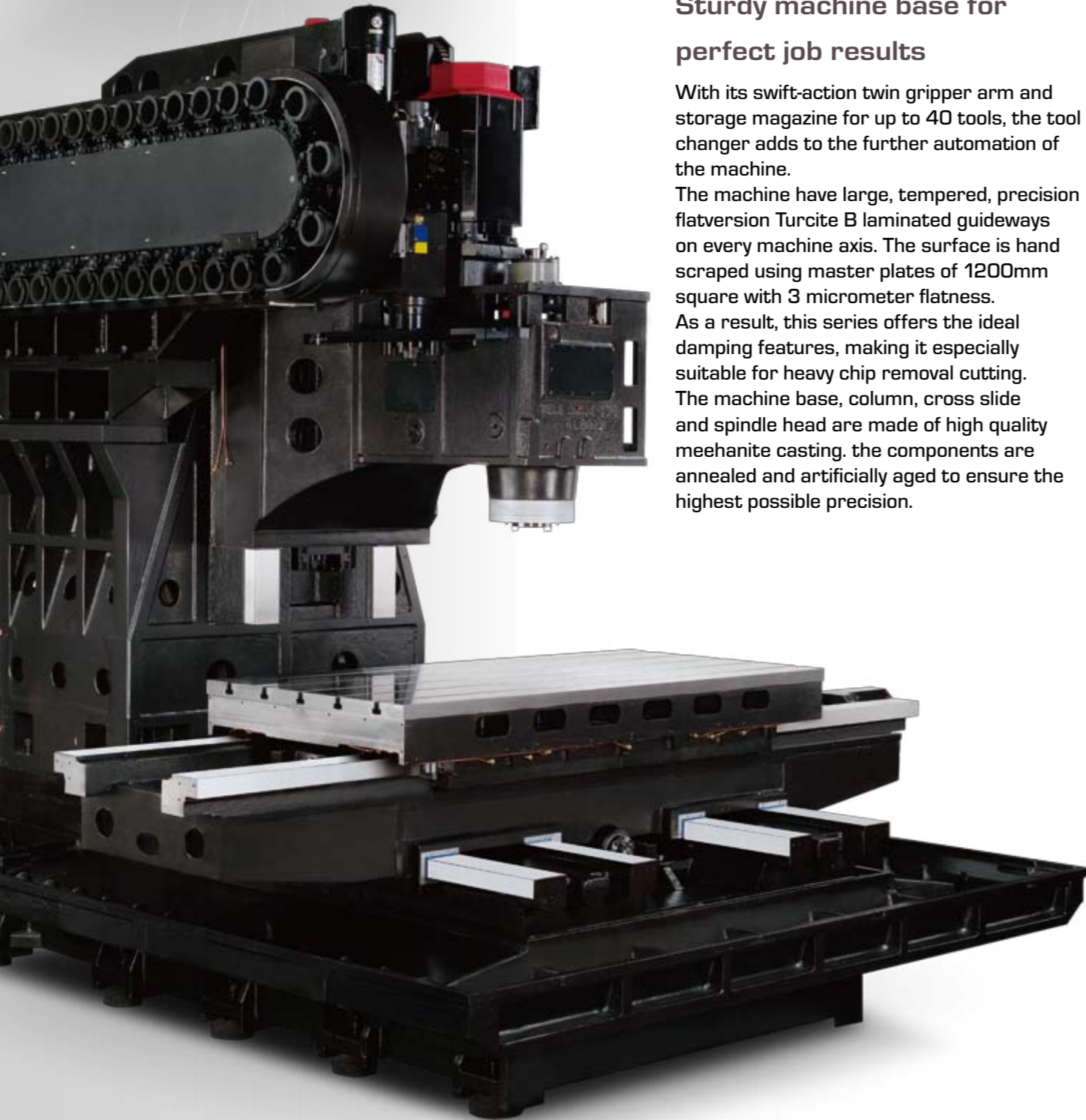

Sturdy machine base for perfect job results

With its swift-action twin gripper arm and storage magazine for up to 40 tools, the tool changer adds to the further automation of the machine.

The machine have large, tempered, precision flatversion Turcite B laminated guideways on every machine axis. The surface is hand scraped using master plates of 1200mm square with 3 micrometer flatness.

As a result, this series offers the ideal damping features, making it especially suitable for heavy chip removal cutting. The machine base, column, cross slide and spindle head are made of high quality meehanite casting. the components are annealed and artificially aged to ensure the highest possible precision.

The full equipment

The basic configuration includes every vital component required for demanding machining.

Details:

- Electronic handwheel with axis selector.
- Precision spindle with directly coupled drive motor
- Integrated spindle oil cooler, temperature controlled via sensors
- Automatic tool change with swing arm; 30 or 40 tool pockets with directional logic.
- Digitally controller AC servo motors with encoder in the X, Y and Z axis.



High performance chip discharge using Y direction screw type conveyors and X direction caterpillar type conveyor.

- Central lubrication system for all guideways and ball screws
- Coolant unit for exterior cooling
- Chip flush system and 2 * Y direction screw type conveyors in the working envelope.
- Interior Form A coolant through spindle supply, pump capacity of 20 bar as option
- Caterpillar type chip conveyor to discharge chip from the machine
- Air blast during tool change
- Air nozzle for dry machining
- Cooling water gun and air gun for cleaning operations in the working area.
- Roof enclosure splash guarding
- Preparation of electrical equipment for 4th axis connectivity
- Working lights
- Signal lamp indicating machine status.
- Alignment element for setting up and aligning the machine
- Transformer

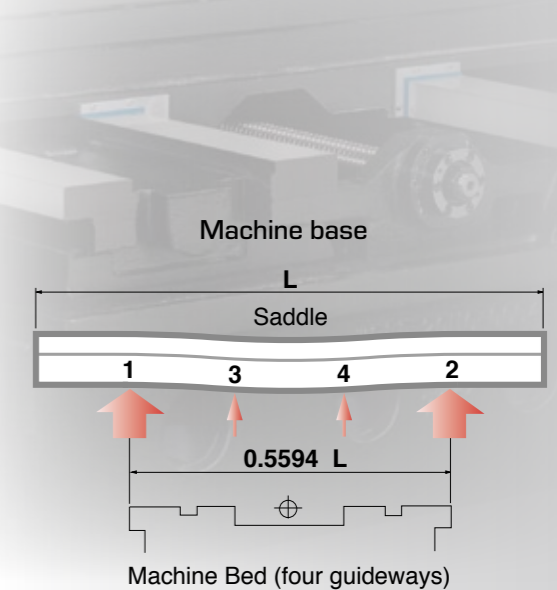

Fig.: Machine base AA1680

		AA1480	AA1680	AA1880
Features				
Stroke X/Y/Z	mm(in)	1400x800x700(55.1x31.5x27.6)	1600x800x800(63x31.5x31.5)	1800x800x800(70.9x31.5x31.5)
Table size LxW	mm(in)	1550x800(61x31.5)	1750x800(68.9x31.5)	1950x800(76.8x31.5)
Workpiece wieght max.	kg(lb)	1800(3960)	2000(4400)	2200(4840)

AA1480	AA1680	AA1880	AA 65 Series	AA 80 Series	AA 90 Series	AQ 50 Series	AQ 60 Series	UG Series	
			RB Series	SB Series	LB Series	MB Series	HB Series	UB Series	MG Series

Guides and drives

The machines come with double nuts , pre-tension ball screws in all 3 axes. Every drive motor is directly coupled to the ball screws and incorporates an integrated feedback system. A variety of precision spindles are available for the core of the machine.

The version supplying BT50 taper is equipped with an upstream, directly coupled, two speed mechanical geared head for speed up to 6000rpm.

A two speed geared head running at 8000rpm is also available for the spindle taper BT#40.

Additional versions incorporating direct drive precision spindles with up to 15000 rpm can also be provided for high speed machining operations.

Spindles

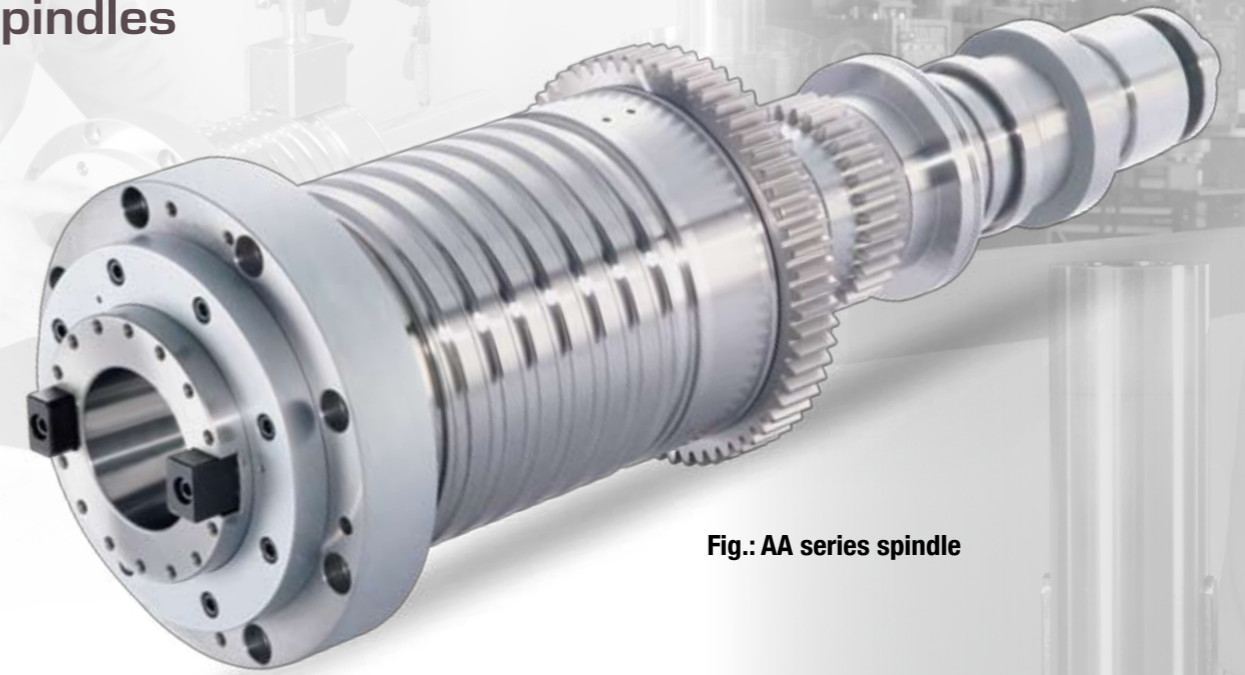
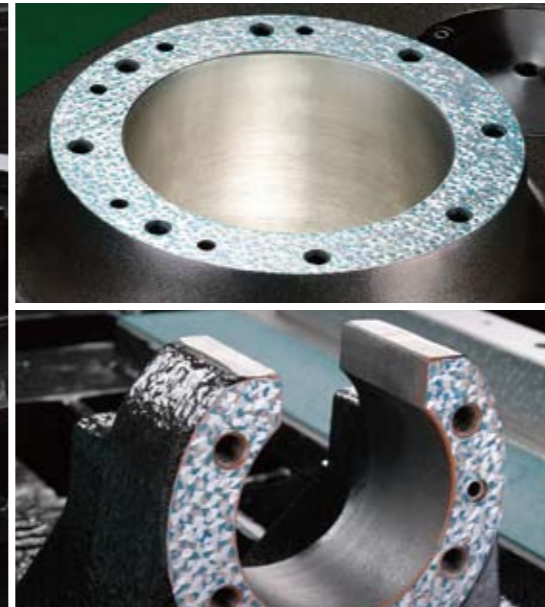

Fig.: AA series spindle

To ensure the machines successfully master heavy-duty or combined rough machining/finish jobs, this version has been fitted with two speed mechanical geared head.

If small tools are also using frequently, the machine can also be supplied with direct drive for higher maximum speed.



Hand scraped contact areas, minimal axis protection with maximum stroke.

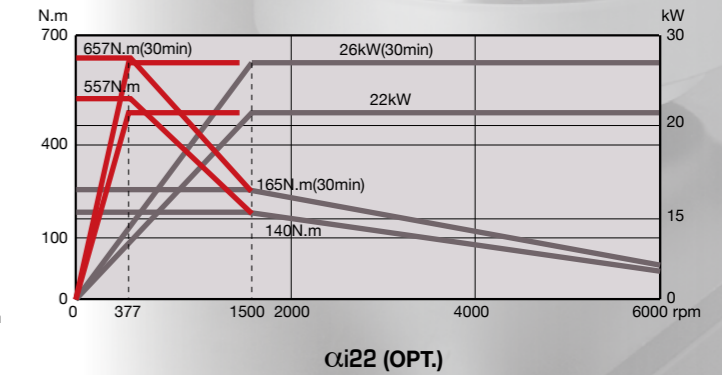
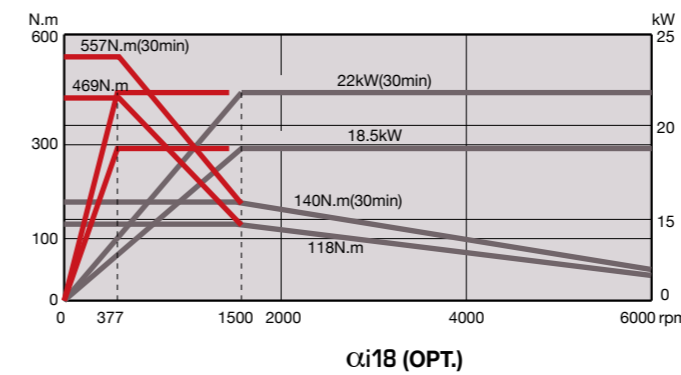
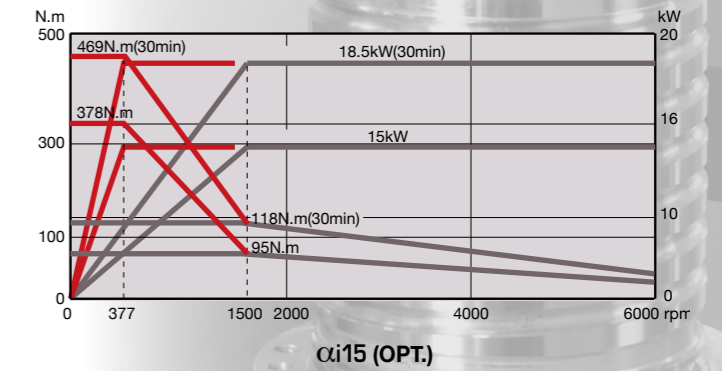
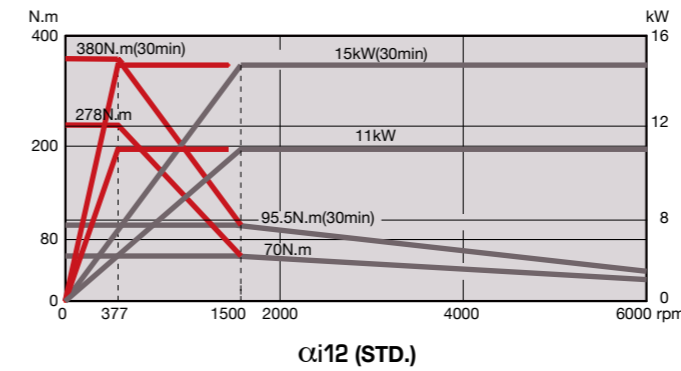

AA1480	AA1680	AA1880	AA 65 Series	AA 80 Series	AA 90 Series	AQ 50 Series	AQ 60 Series	UG Series	
			RB Series	SB Series	LB Series	MB Series	HB Series	UB Series	MG Series

User-friendly down to the last detail



Ergonomic design

The layout and design of the control panel as well as access to the working envelope have been defined by machine operators with experience in the field. In addition to the swivel/rotating control panel with angled keyboard, especially wide opening working envelope door have been reduced to an absolute minimum. Even with very large workpiece, over head crane loads can be easily swung over to the middle of the table.



Easy clean

To clean the interior and working envelope, the machine comes equipped with a front access purge spray gun and air blast located at the left and right, both of which are within easy reach.

High Efficiency Cutting Performance

AA 965 Gear driven spindle BT40 / 8000 rpm / AC 15/18.5 kW (OPT) Material: S45C

Face milling	ø100x6t
Spindle speed (S)	400 rpm
Cutting velocity (Vc)	126 m/min
Cutting width (ae)	80 mm
Cutting depth (ap)	5.5 mm
Cutting feedrate (Vf)	1200 mm/min
Cutting feedrate per tip (fz)	0.5 mm/tooth
Cutting capacity (MRR)	528 cc/min
Cutting capacity per kW (MRR/kW)	35 cc/min · kW



End milling ø32x2t	Side milling	Slot milling
Spindle speed (S)	1500 rpm	1500 rpm
Cutting velocity (Vc)	150 m/min	150 m/min
Cutting width (ae)	16 mm	32 mm
Cutting depth (ap)	32 mm	16 mm
Cutting feedrate (Vf)	400 mm/min	400 mm/min
Cutting feedrate per tip (fz)	0.13 mm/tooth	0.13 mm/tooth
Cutting capacity (MRR)	205 cc/min	205 cc/min



Drilling ø33	Use 20 bar CTS (Opt)
Spindle speed (S)	2000 rpm
Cutting velocity (Vc)	207 m/min
Cutting feedrate (Vf)	250 mm/min
Cutting feedrate per tip (fz)	0.125 mm/rev
Cutting capacity (MRR)	214 cc/min



Rigid tapping	M30xP3.5	M4xP0.7
Spindle speed (S)	180 rpm	2000 rpm
Cutting feedrate (Vf)	630 mm/min	1400 mm/min



AA1480	AA1680	AA1880	AA 65 Series	AA 80 Series	AA 90 Series	AQ 50 Series	AQ 60 Series	UG Series	
			RB Series	SB Series	LB Series	MB Series	HB Series	UB Series	MG Series

Strictly quality assurance



Strictly manufacturing and assembling in precision and control every detail as Japanese standard

Pursue quality, approaching makes excessive demands

US Moore Artisan spirit - Holds the breath with rapt attention to finish all detail.

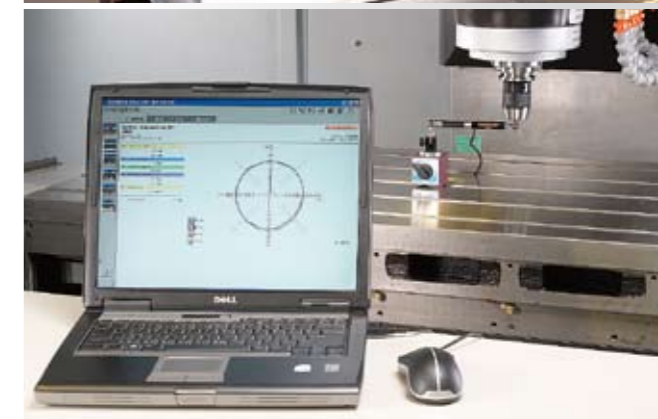

AA1480	AA1680	AA1880	AA 65 Series	AA 80 Series	AA 90 Series	AQ 50 Series	AQ 60 Series	UG Series	
			RB Series	SB Series	LB Series	MB Series	HB Series	UB Series	MG Series

Technical specifications

Specification/Model	Unit	AA1480	AA1680	AA1880
Travel				
X travel (left & right)	mm(in)	1400(55.1)	1600(63)	1800(70.9)
Y travel (in & out)	mm(in)	800(31.5)		
Z travel (up & down)	mm(in)	700(27.6)	800(31.5)	
Distance from spindle nose to table top	mm(in)	200-900(7.9-35.4)	200-1000(7.9-39.4)	
Table				
Table size (X direction)	mm(in)	1550(61.0)	1750(68.9)	1950(76.8)
Table size (Y direction)	mm(in)	800(31.5)		
Table load capacity	kg(lb)	1800(3960)	2000(4400)	2200(4840)
Spindle				
Spindle speed	rpm	Belt driven / 6000		
Spindle motor (cont./30 min. rating)	kW(HP)	11/15(15/20)		
Spindle taper		BT#50		
Feedrate				
Rapid traverse rate (X axis)	mm(in)/min	15000(590.6)		
Rapid traverse rate (Y axis)	mm(in)/min	15000(590.6)		
Rapid traverse rate (Z axis)	mm(in)/min	12000(472.4)		
Cutting feedrate	mm(in)/min	1-8000(0.04-315)		
Tool magazine				
Tool magazine capacity	pcs	16		
Max. tool diameter / adjacent pocket empty	mm(in)	110/200(4.3/7.9)		
Max. tool length	mm(in)	300(11.8)		
Max. tool weight	kg(lb)	15(33)		
Accuracy				
Positioning accuracy (VDI/DGQ 3441)	mm(in)	P 0.015(0.0006)		
Repeatability accuracy (VDI/DGQ 3441)	mm(in)	Ps 0.008(0.0003)		
Space requirement & weight				
Machine length	mm(in)	4050(159.4)	4450(175.2)	4850(190.9)
Machine width	mm(in)	3100(122.0)	3140(123.6)	3140(123.6)
Machine height	mm(in)	3343(131.6)	3478(136.9)	3478(136.9)
Machine weight	kg(lb)	12000(26400)	16000(35200)	18000(39600)

Standard and optional accessories

● : Standard ○ : Option X : Not available

Specification / Model	AA1480	AA1680	AA1880
BT40 spindle taper	○	○	○
BT50 spindle taper	●	●	●
DIN50 spindle taper	○	○	○
CAT50 spindle taper	○	○	○
6,000 rpm belted spindle (BT#50)	●	●	●
6,000 rpm geared spindle (BT#50)	○	○	○
8,000 rpm belted spindle (BT#40)	○	○	○
8,000 rpm geared spindle (BT#40)	○	○	○
8,000 rpm direct driven spindle (20/25HP) BBT50	○	○	○
10,000 rpm direct driven spindle (20/25HP) BBT50	○	○	○
12,000 rpm direct driven spindle (20/25HP) BBT40	○	○	○
15,000 rpm direct driven spindle (20/25HP) BBT40	○	○	○
Column raise up for 200mm	○	○	○
Spindle & gearbox temperature control system	●	●	●
External pulse coder	●	●	●
Centralized automatic lubricating system	●	●	●
Roof enclosure guarding system	●	●	●
Flood Coolant system (Pump & tank)	●	●	●
Recycling lubricating oil collector for 3 axes	●	●	●
Chip auger	●	●	●
Caterpillar type conveyor and bucket	○	○	○
16 capacity of umbrella type tool magazine (Tool holder #40)	●	●	●
24 capacity of arm type tool magazine (Tool holder #40,#50)	○	○	○
30 capacity of arm type tool magazine (Tool holder #40,#50)	○	○	○
40 capacity of arm type tool magazine (Tool holder #40,#50)	○	○	○
Rigid tapping	●	●	●
Switch for manual tool clamping	●	●	●
Remote handwheel control	●	●	●
Work light	●	●	●
Operation cycle finish and alarm lights	●	●	●
RS232 interface	●	●	●
Spray hose for chip wash down	●	●	●
Foundation bolt kit	●	●	●
Machine manuals	●	●	●
Linear scale feedback system for 3 axes	○	○	○
Coolant through the tool adapter	○	○	○
Coolant through the spindle (Form A) with 520 liter high tank	○	○	○
Automatic tool length measurement (Renishaw or Blum)	○	○	○
Automatic workpiece measuring system (Renishaw or Blum)	○	○	○
CNC rotary table	○	○	○
4th axis interface prepared	○	○	○
FANUC 0iM controller	●	●	●
FANUC 18iM controller	○	○	○
Heidenhain TNC i530 controller	○	○	○

AA1480	AA1680	AA1880	AA 65 Series	AA 80 Series	AA 90 Series	AQ 50 Series	AQ 60 Series	UG Series	
			RB Series	SB Series	LB Series	MB Series	HB Series	UB Series	MG Series

Tool Shank and Pull Stud Dimension

Unit : mm(inch)

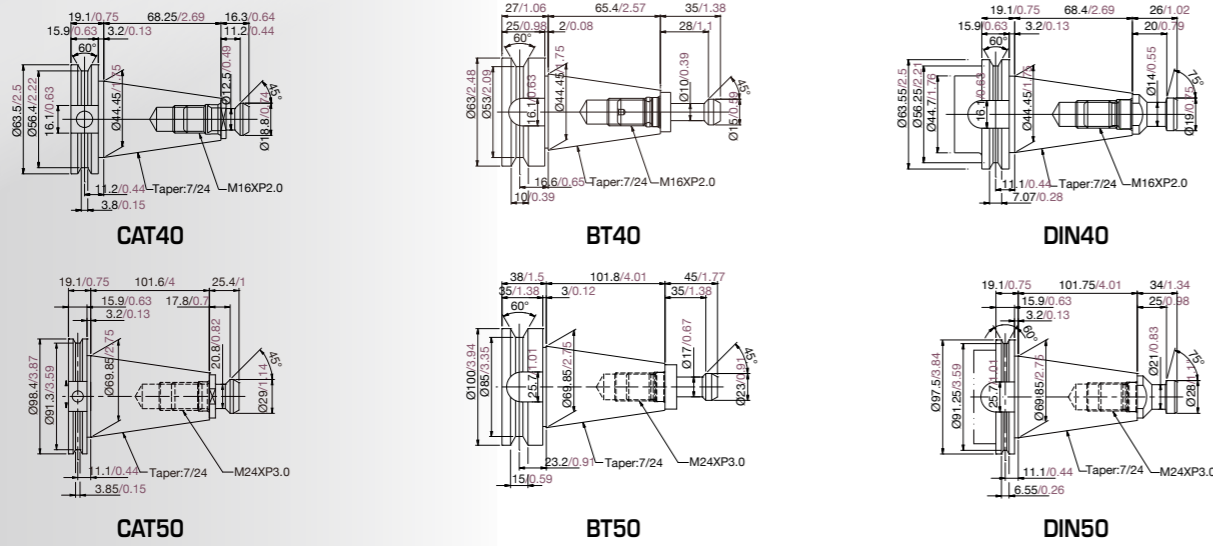

Inside of Working Area Dimensions

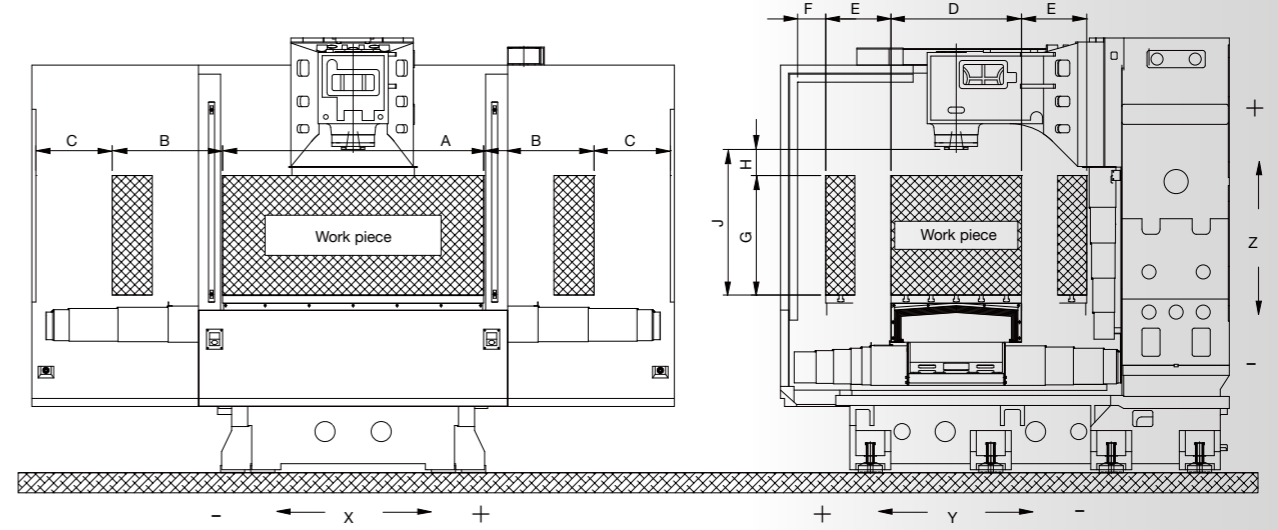

Machine Dimension and Space Requirement

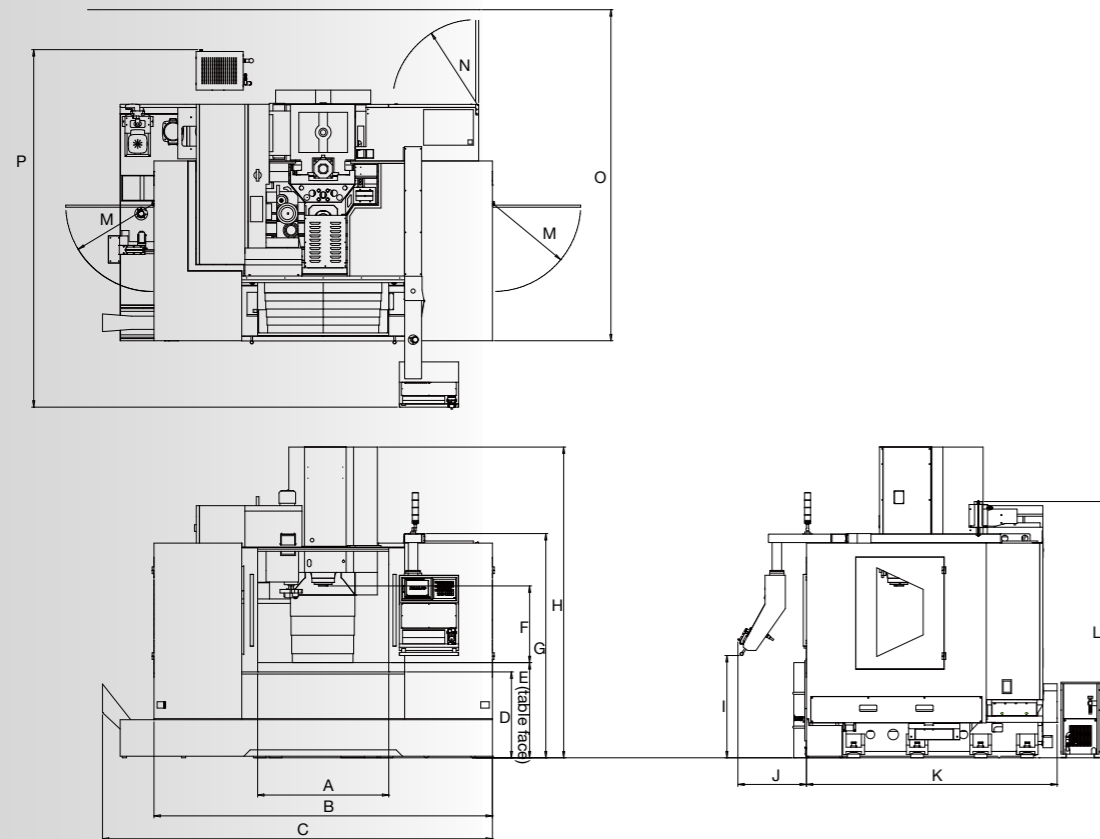

Unit : mm(inch)

	A	B	C	D	E	F	G	H	I	J	K	L	M	N	O	P
AA1480	1570 (61.8)	4050 (159.4)	4250 (167.3)	762 (30)	1000 (39.4)	900 (35.4)	2435 (95.9)	3343 (131.6)	980 (38.6)		3100 (122)	2910 (114.6)			3525 (138.8)	3720 (146.5)
AA1680	1770 (69.7)	4450 (175.2)	4650 (183.1)	803 (31.6)	1036 (40.8)	1000 (39.4)	2506 (98.7)	3478 (136.9)	1050 (41.3)	620 (24.4)	3140 (123.6)	3056 (120.3)	972 (38.3)	650 (25.6)	3620 (142.5)	3760 (148)
AA1880	1970 (77.6)	4850 (190.9)	5050 (198.8)	803 (31.6)	1036 (40.8)	1000 (39.4)	2506 (98.7)	3478 (136.9)	1050 (41.3)		3140 (123.6)	3056 (120.3)			3620 (142.5)	3760 (148)

Unit : mm(inch)

	A	B	C	D	E	F	G	H	J
AA1480	1550(61)	700(27.6)	513(20.2)	800(31.5)	400(15.7)	217(8.5)	695(27.4)	205(8.1)	200~900(7.9~35.4)
AA1680	1750(68.9)	800(31.5)	513(20.2)	800(31.5)	400(15.7)	242(9.5)	795(31.3)	205(8.1)	200~1000(7.9~39.4)
AA1880	1950(76.8)	800(31.5)	513(20.2)	800(31.5)	400(15.7)	242(9.5)	795(31.3)	205(8.1)	200~1000(7.9~39.4)

Table Dimensions

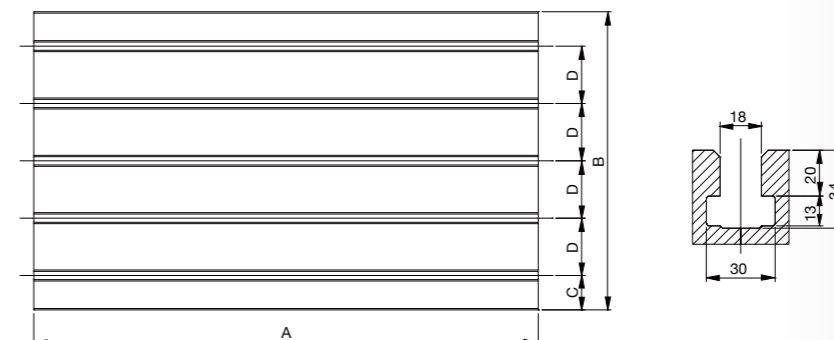

Unit : mm(inch)

	A	B	C	D
AA1480	1550(61)	800(31.5)	100(3.9)	150(5.9)
AA1680	1750(68.9)	800(31.5)	100(3.9)	150(5.9)
AA1880	1950(76.8)	800(31.5)	100(3.9)	150(5.9)